

기사의 용량계수	기사의 도색여부	1	2	3	4	5	6
기사의 용량계수 C = 0.3~1.2 R = 0.3~1.2	기사의 도색여부 기사의 도색여부	0.5 6	30 120	315 1200	1000 2000	1000 2000	1000 2000
기사의 용량계수	기사의 도색여부	0.5 6	30 120	315 1200	1000 2000	1000 2000	1000 2000
기사의 용량계수	기사의 도색여부	0.5 6	30 120	315 1200	1000 2000	1000 2000	1000 2000

MARK	REASONABLE REVISIONS	DATE	DRAWN	APPR'D

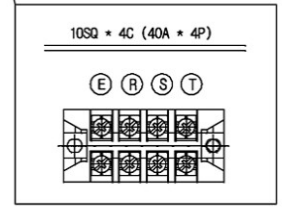
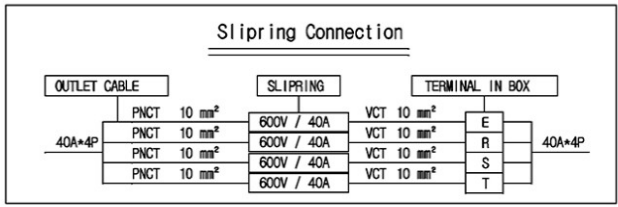
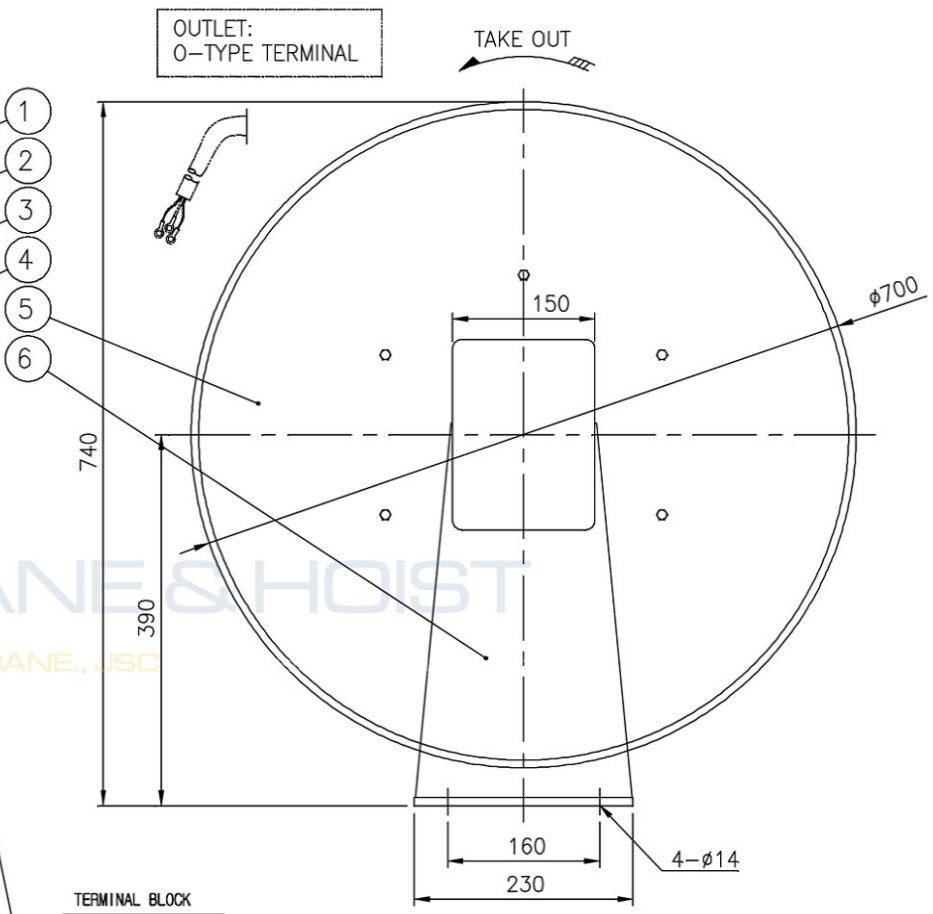
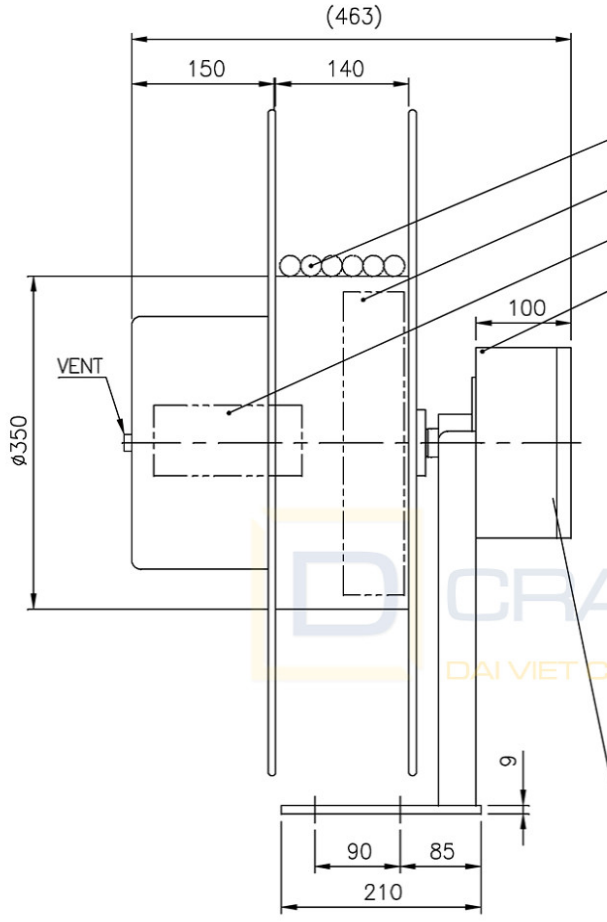
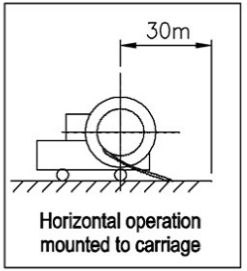
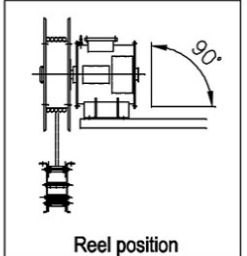
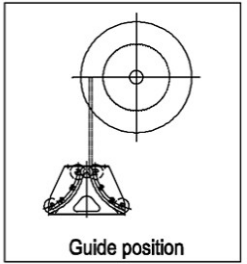

SPECIFICATION

- 1. Cable
 - o Spec. : PNCT 10SQ x 4C
 - o Size : approx. ø21.9 mm
 - o Weight : approx. 0.84 kg/m
 - o Length : 35 M
- 2. Winding Length : 30 M
- 3. Winding Speed : max. 20 M/Min.
- 4. Winding Torque : 2 kg.m
- 5. Slip Ring : 40A x 4P
- 6. Paint Color : M/No. 7.5 BG 6/1.5
- 7. Setting Height : Max. 1.0 M from G.L.
- 8. Q'ty : 1 Set

6	-	FRAME	SPHC	1	
5	-	DRUM	SPCC	2	
4	-	TERMINAL BOX	PLASTIC	1	
3	-	SLIP RING	C3771	4	
2	-	SPRING	ATX	2	
1	-	CABLE	PNCT	35M	

ITEM	PART NO.	PART NAME	MATERIAL	Q'ty	REMARKS
PROJECTION	DIMENSION UNIT	SCALE	MODEL		
3rd ANGLE	METRIC (mm)	1:8	ECC-1035-4		
CUSTOMER	PART NAME		외형도		
MODEL COLOR	M/NO. 7.5BG 6/1.5	PART NO.		A471-7000	
DRAWING	DESIGN	CHECK	APPROVAL		
SIGN	K.B.S				
DATE	2019.08.26				

